

H(cm)	3CS 80/XXX 400
H(B)	85
H(E)	50
H(U)	40,55,105,130
H(C)	125, 140, 175, 190, 215 240, 265, 290, 315, 340 365, 390

ϕ	ϕ min	ϕ max
315	313.8	316
400	398.6	400.9

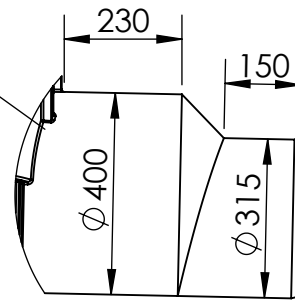

DETAIL B
SCALE 1 : 15

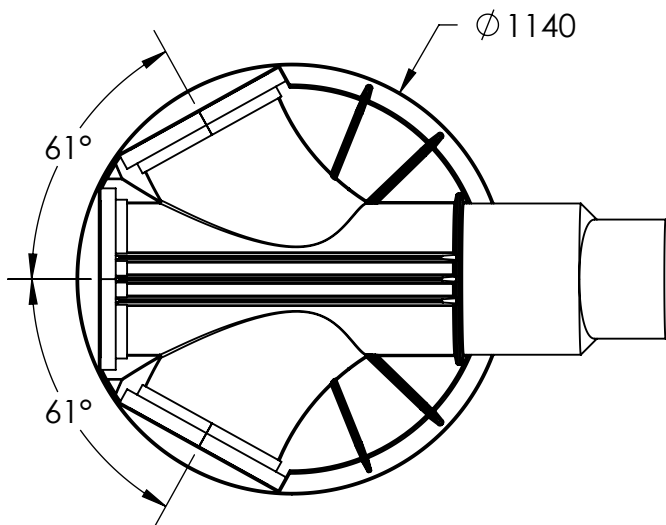